

# *Cardiodrive* Installation, Operation and Service Manual



710 N. Tucker Blvd  
Suite 110  
St. Louis, MO 63101 USA  
1-866-646-2346  
1-314-678-6100  
[www.stereotaxis.com](http://www.stereotaxis.com)

Made in USA

© Stereotaxis 2010, 2023

R<sub>Only</sub>  
CE 2797

---

## Contact Stereotaxis

---

Stereotaxis, Inc.  
710 N. Tucker Blvd  
Suite 110  
St. Louis, MO 63101  
USA  
www.stereotaxis.com  
1-314-678-6100 (*Stereotaxis – US*)  
0031.75.77.133.13 (*Stereotaxis – EU*)  
1-314-678-6200 (*TeleRobotic Support Team – US*)



Made In USA

---

## EC Representative

---

MDSS  
(Medical Device Safety Service GmbH)  
Schiffgraben 41  
30175 Hannover, Germany



---

## UK Representative

---

MDSS-UK RP LIMITED  
6 Wilmslow Road, Rusholme  
Manchester M14 5TP  
United Kingdom  
Tel.: 0044 (0)7898 375115

**UKRP**

---

## Importer

---

MedEnvoy  
Prinses Margrietplantsoen  
33 - Suite 123,  
2595 AM The Hague  
Netherlands



---

## Patents

---

Manufactured under one or more of the following patents:

*United States*

7,066,924; 7,635,342; 7,766,856

*European*

EP 1 389 958 (B1)

EP 1 781 364 (A2)

## Trademarks

---

- *Cardiodrive* and *Niobe* are trademarks of Stereotaxis, Inc., registered in the United States, the European Community, and Japan.
- *Genesis* and *QuikCAS* are trademarks of Stereotaxis, Inc.

All other brand names, product names, or trademarks are the property of their respective owners.

## EMC Directive Statement

---

EMC Directive Compliance This equipment was tested and found to conform to the Medical Directive 93/42/EEC for electromagnetic compatibility. Compliance with this Directive is based upon compliance with the following harmonized standards:

Emissions:	IEC 60601-1-2:2007, EN55011, FCC Part 15.107(a) & ICES-003, EN61000-3-2:2006 +A1:2009 +A2:2009, EN61000-3-3:2013
Immunity:	EN 60601-1-2:2015, EN61000-4-2:2009, EN61000-4-3:2006 +A1:2008 +A2:2010, EN61000-4-4:2012, EN61000-4-5:2006, EN61000-4-6:2009, EN61000-4-8:2010, EN61000-4-11:2004

When operating this equipment, verify that other devices installed near it conform to the applicable EMC standards for that device.

## Related documents



HDW-0312 – Niobe ES User Guide

HDW-0358 – Genesis User Guide



**WARNING:** No modification of this equipment is allowed. No user-serviceable parts are inside the *Cardiodrive* system. The user should not attempt to disassemble any portion of the *Cardiodrive*.



**WARNING:** To avoid the risk of electric shock, this equipment must only be connected to a supply mains that have a protective earth ground.

## Disposal

---

This product should be recycled and not disposed of as general waste (subject to WEEE annex IV resp. EN 50419).

## Waste and Recycling

---

A contractor is responsible for the disposal and recycling of scrap metals and electronics found in the *Cardiodrive* system.

Suggested Contractor: Walch Recycling & Eldementalle



**Notice to the User and/or Patient**

---

Any serious incident that has occurred in relation to the device should be reported to the manufacturer and the competent authority of the Member State in which the user and/or patient is established.

**Cover art**

---

Cover art © 2019, 2022 Stereotaxis, Inc.

## Contents

---

<b>Introduction .....</b>	<b>1</b>
About the <i>Cardiodrive</i> System.....	1
Intended Use .....	1
Intended Patient Population .....	1
Intended User.....	1
Companion Magnetic Navigation System .....	1
About This User Guide .....	2
Safety .....	2
Electromagnetic Compatibility Information .....	3
Definitions.....	6
Graphics and Symbols .....	7
<b>Configuring the <i>Cardiodrive</i> System .....</b>	<b>10</b>
System Components.....	10
System Interconnection .....	10
Installing the Motor Assembly Mounting Hardware.....	11
Installing the Motor (030-005115) .....	12
Installing the Disposable Advancer Unit (001-001751-1).....	12
<b><i>Cardiodrive</i> Instructions for Use.....</b>	<b>13</b>
Powering Up <i>Cardiodrive</i> Unit.....	13
Powering Down <i>Cardiodrive</i> Unit .....	13
<b>Performance Specifications .....</b>	<b>13</b>
Additional Information .....	13
<b><i>Cardiodrive</i> Maintenance .....</b>	<b>13</b>
Cleaning .....	13
<b>Index.....</b>	<b>14</b>

## Figures

---

Figure 1. <i>Cardiodrive</i> Advancer Unit.....	10
Figure 2. <i>Cardiodrive</i> interconnect diagram .....	11
Figure 3. Motor Assembly mounting hardware installation .....	12

## Tables

---

Table 1. Glossary .....	6
Table 2. Graphics and symbols.....	7
Table 3. CAS performance specifications .....	13

## Introduction

### About the *Cardiodrive* System

The Stereotaxis *Cardiodrive*® catheter advancement system (CAS) is a tool that provides the physician with the ability and the choice to advance and retract catheters from a control room.

### Intended Use

**In the United States and Canada, the following Indications are applicable for the *Cardiodrive* system.**

- The Stereotaxis *Cardiodrive* system is intended for automatically advancing and retracting only compatible magnetic electrophysiology (EP) mapping and ablation catheters inside the patient's heart when used in conjunction with a Stereotaxis Robotic Magnetic Navigation System (RMNS).
- The *Cardiodrive* system is not intended to advance the EP mapping and ablation catheters through the coronary vasculature or the coronary sinus.

**In all other geographies, the following Indications are applicable for the *Cardiodrive* system.**

The Stereotaxis *Cardiodrive* system is intended for automatically advancing and retracting only compatible magnetic electrophysiology (EP) mapping and ablation catheters inside the patient's heart and pericardial space when used in conjunction with a Stereotaxis RMNS.

### Intended Patient Population

The intended patient population for *Cardiodrive* is patients undergoing EP mapping and ablation procedures of the heart.

### Intended User

*Cardiodrive* should be used only by qualified medical professionals who have been thoroughly trained in its use.

### Companion Magnetic Navigation System

The *Cardiodrive* system works in conjunction with a magnetic navigation system. The physician uses the RMNS to steer the distal tip of the catheter while the *Cardiodrive* device provides the means for remote advancement or retraction. A companion x-ray system provides real-time guidance for the physician during the interventional procedure as well. The documentation for the RMNS and the x-ray system are not duplicated herein.

The Instructions for Use (IFU) for the *Cardiodrive* disposables are provided in appendixes following the body of this guide and are contained in its binder.

## About This User Guide







The purpose of this guide is to provide the user of the *Cardiodrive* system with instructions for operating the equipment.

The user guide provides information for configuring, powering up, operating, and shutting down the Stereotaxis *Cardiodrive* system (P/N 001-004115). It also provides information on the installation and maintenance of the *Cardiodrive* unit.




## Safety

Although the *Cardiodrive* system provides for remote advancement and retraction of compatible devices, it does not replace the physician's knowledge, expertise, or judgment.

### Warnings

-  **WARNING:** Federal (USA) law restricts this device to sale by or on the order of a physician.
-  **WARNING:** The Stereotaxis *Cardiodrive* system should be used only by physicians trained in electrophysiology, interventional cardiology, and in the use of the *Cardiodrive* device and the Stereotaxis magnetic navigation system.
-  **WARNING:** The Stereotaxis *Cardiodrive* system should only be used by physicians trained in electrophysiology, interventional cardiology, and in the use of the *Cardiodrive* device and the Stereotaxis magnetic navigation system.
-  **WARNING:** Always verify catheter motion using live fluoroscopy images. Stop immediately if catheter motion can no longer be verified.
-  **WARNING:** Do not remove covers or attempt to service any of the components of the *Cardiodrive* system. Refer all servicing to qualified service personnel.
-  **WARNING:** Always verify operation of the *Cardiodrive* system before beginning any procedure. Refer to Section 3 of this user guide.

### Precautions

-  **CAUTION:** Do not bring the Motor Assembly within 2 feet of the magnet used in the magnetic navigation system.
-  **CAUTION:** When performing a retrograde approach to the left heart via the ascending aorta, please cross the aortic valve and the mitral valve manually, not by the *Cardiodrive* component of the Stereotaxis RMNS.
-  **CAUTION:** As with manual catheter advancement, when advancing the



catheter with *Cardiodrive* system, the catheter speed should be decreased to an appropriate speed when approaching vascular structure (such as pulmonary veins) or coronary artery/vein ostia. As a reminder, the maximum advancement speed of the *Cardiodrive* device is 2.0 cm/second.

## Electromagnetic Compatibility Information



**WARNING:** The use of accessories, transducers, and cables other than those specified, with the exception of transducers and cables sold by Stereotaxis, Inc., may result in increased emissions or decreased immunity of the *Cardiodrive* system.



**WARNING:** The *Cardiodrive* system should not be used adjacent to or stacked with other equipment and, if adjacent or stacked use is necessary, the *Cardiodrive* system should be observed to verify normal operation in the configuration in which it will be used.

## Emissions

The *Cardiodrive* system is intended for use in the electromagnetic environment specified in the following tables. The customer or the user of the *Cardiodrive* system should ensure that it is used in such an environment.

The following table provides guidance and Stereotaxis' declaration on **electromagnetic emissions** for the *Cardiodrive* system:

Emissions	Compliance	Electromagnetic environment—guidance
RF emissions EN55011	Group 1	The <i>Cardiodrive</i> system uses RF energy only for its internal function. Therefore, its RF emissions are very low and are not likely to cause any interference in nearby electronic equipment.
RF emissions EN55011	Class A Complies	
Harmonic emissions IEC 61000-3-2		
Voltage fluctuations/ flicker emissions IEC 61000-3-3		



**WARNING:** The EMISSIONS characteristics of this equipment make it suitable for use in industrial and hospital (CISPR 11 class A) settings. If it is used in a residential environment (for which CISPR 11 class B is normally required), this

equipment might not offer adequate protection to radio-frequency communication services. The user might need to take mitigation measures, such as relocating or re-orienting the equipment.

## Immunity—General electromagnetic effects


The following table provides guidance and Stereotaxis' declaration on **electromagnetic immunity** regarding general electromagnetic effects for the *Cardiodrive* system:

Immunity test	IEC 60601 test level*	Compliance level*	Electromagnetic environment—guidance
Electrostatic discharge (ESD) IEC 61000-4-2	± 6 kV contact ± 8 kV air	± 6 kV contact ± 8 kV air	Floors should be wood, concrete, or ceramic tile. If floors are covered with synthetic material, the relative humidity should be at least 30%.
Electrical fast transient/burst IEC 61000-4-4	± 2 kV for power supply lines ± 1 kV for input/output lines	± 2 kV for power supply lines ± 1 kV for input/output lines	Mains power quality should be that of a typical commercial or hospital environment.
Surge IEC 61000-4-5	± 1 kV line(s) to line(s) ± 2 kV line(s) to earth	± 1 kV line(s) to line(s) ± 2 kV line(s) to earth	Mains power quality should be that of a typical commercial or hospital environment.
Voltage dips, short interruptions and voltage variations on power supply input lines IEC 61000-4-11	<5 % $U_T$ (>95 % dip in $U_T$ ) for 0.5 cycle 40 % $U_T$ (60 % dip in $U_T$ ) for 5 cycles 70 % $U_T$ (30 % dip in $U_T$ ) for 25 cycles <5 % $U_T$ (>95 % dip in $U_T$ ) for 5 s	<5 % $U_T$ (>95 % dip in $U_T$ ) for 0.5 cycle 40 % $U_T$ (60 % dip in $U_T$ ) for 5 cycles 70 % $U_T$ (30 % dip in $U_T$ ) for 25 cycles <5 % $U_T$ (>95 % dip in $U_T$ ) for 5 s	Mains power quality should be that of a typical commercial or hospital environment. If the user of the <i>Cardiodrive</i> system requires continued operation during power mains interruptions, it is recommended that the <i>Cardiodrive</i> system be powered from an uninterruptible power supply or a battery.
Power frequency (50/60 Hz) magnetic field IEC 61000-4-8	3 A/m	3 A/m	Power frequency magnetic fields should be at levels characteristic of a typical location in a typical commercial or hospital environment.

\*  $U_T$  is the a.c. mains voltage before application of the test level.

## Immunity—RF interference

The following table provides guidance and Stereotaxis' declaration on **electromagnetic immunity** regarding RF frequency for the *Cardiodrive* system:

Immunity test	IEC 60601 test level	Compliance level	Electromagnetic environment—guidance
Conducted RF IEC 61000-4-6	3 Vrms 150 kHz to 80 MHz	3 V	Portable and mobile RF communications equipment should be used no closer to any part of the <i>Cardiodrive</i> system, including cables, than the recommended separation distance calculated from the equation applicable to the frequency of the transmitter.  <b>Recommended separation distance</b> $d = 1.2\sqrt{P}$ $d = 1.2\sqrt{P}$ 80 MHz to 800 MHz $d = 2.3\sqrt{P}$ 800 MHz to 2.5 GHz where $P$ is the maximum output power rating of the transmitter in watts (W) according to the transmitter manufacturer and $d$ is the recommended separation distance in meters (m).  Field strengths from fixed RF transmitters, as determined by an electromagnetic site survey, <sup>a</sup> should be less than the compliance level in each frequency range. <sup>b</sup>  Interference may occur in the vicinity of equipment marked with the following symbol :  
Radiated RF IEC 61000-4-3	3 V/m 80 kHz to 2.5 GHz	3 V/m	

**Note 1:** At 80 MHz and 800 MHz, the higher frequency range applies.

**Note 2:** These guidelines may not apply in all situations. Electromagnetic propagation is affected by absorption and reflection from structures, objects, and people.

<sup>a</sup> Field strengths from fixed transmitters, such as base stations for radio (cellular/cordless) telephones and land mobile radios, amateur radio, AM and FM radio broadcast, and TV broadcast cannot be predicted theoretically with accuracy. To assess the electromagnetic environment due to fixed RF transmitters, an electromagnetic site survey should be considered. If the measured field strength in the location in which the *Cardiodrive* system is used exceeds the applicable RF compliance level above, the *Cardiodrive* system should be observed to verify normal operation. If abnormal performance is observed, additional measures may be necessary, such as re-orienting or relocating the *Cardiodrive* system or needing to contact the TeleRobotic Support Team.

- <sup>b</sup> Over the frequency range 150 kHz to 80 MHz, field strengths should be less than 3 V/m.

## Separation Distances

The *Cardiodrive* system is intended for use in the electromagnetic environment in which radiated RF disturbances are controlled. The customer or the user of the *Cardiodrive* system can help prevent electromagnetic interference by maintaining a minimum distance between portable and mobile RF communications equipment (transmitters) and the *Cardiodrive* system as recommended in the following table, according to the maximum output power of the communications equipment.

Rated maximum output power of transmitter* W	Separation distance according to frequency of transmitter m		
	150 kHz to 80 MHz $d = 1.2\sqrt{P}$	80 MHz to 800 MHz $d = 1.2\sqrt{P}$	800 MHz to 2.5 GHz $d = 2.3\sqrt{P}$
0.01	0.12	0.12	0.23
0.1	0.38	0.38	0.73
1	1.2	1.2	2.3
10	3.8	3.8	7.3
100	12	12	23

## Definitions




The glossary in **Table 1** defines terms in this user guide.

**Table 1.** Glossary

Term	Explanation
<b>Advance</b>	Forward direction of travel of device being controlled
<b>Advancer Unit</b>	Disposable component that attaches <i>Cardiodrive</i> unit to device to be advanced or retracted
<b>CAS</b>	<i>Cardiodrive</i> catheter advancement system
<b>EP</b>	Electrophysiology
<b>IFU</b>	Instructions for Use
<b>RMNS</b>	Robotic Magnetic Navigation System
<b>Motor</b>	<i>Cardiodrive</i> component that provides the mechanical force to move device
<b>Retract</b>	Backward direction of travel of device being controlled





## Graphics and Symbols


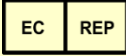







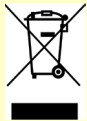

The following graphical symbols (**Table 2**) are used in this document and/or on *Cardiodrive* components:

<b>WARNING</b>		<b>WARNING</b> indicates a potentially hazardous situation which, if not avoided, could result in death or serious injury.
<b>CAUTION</b>		<b>CAUTION</b> indicates a potentially hazardous situation which, if not avoided, could result in injury to patient or operator or damage to the equipment.
<b>Note</b>		<b>Note</b> identifies information that could affect the outcome or results of the procedure.

Warnings and Cautions precede the text and any procedure involving a clear risk to the operator(s), the patient, or the equipment. General warnings are listed in the Warnings and Precautions summary, which can be found in the *Safety* section. Pay close attention to the instructions that accompany the warnings, notes, and symbols.

**Table 2.** Graphics and symbols

Symbol	Name	Description
	<b>AC Power</b>	Indicates the status of the AC power.
<b>REF</b>	<b>Catalogue Number</b>	Catalogue/part number.
	<b>Caution</b>	Indicates the need for the user to consult the instructions for use for important, cautionary information such as warnings and precautions that cannot be presented on the medical device.
	<b>CE Marking</b>	Product conforms to European Medical Directive 93/42/EEC and meets applicable healthy, safety, and environmental requirements. If the mark is accompanied by a number, conformity is valid.
	<b>Consult Instructions</b>	See the Operating Instructions for additional information or instruction.

Symbol	Name	Description
	<b>Date of Manufacture</b>	The date when the medical device was manufactured.
	<b>European Representative</b>	Name and address of the authorized representative in the European Community.
	<b>Importer</b>	Name and address of the entity importing the medical device into the locale.
	<b>Magnet Present</b>	Indicates a magnet is present in the equipment.
	<b>Manufacturer</b>	Name and address of the manufacturer of the product.
	<b>Medical Device</b>	Indicates the item is a medical device.
	<b>Pinch Point</b>	Indicates location of a pinch point.
	<b>Power</b>	Indicates the power status of the component or system.
	<b>Prescription Only</b>	Caution: Federal law restricts this device to sale by or on the order of a physician.
	<b>Recycle: Electronic Equipment</b>	Product that is subject to the European Union's Waste Electrical and Electronic Equipment (WEEE) 2002/96/EC/EU Directive for recycling of electronic equipment.
	<b>Refer to Instruction Manual/Booklet</b>	The instruction manual or booklet must be read.

<b>Symbol</b>	<b>Name</b>	<b>Description</b>
<b>SN</b>	<b>Serial Number</b>	The manufacturer's serial number so a specific medical device can be identified.
<b>UKRP</b>	<b>UK Responsible Person</b>	A person established in the United Kingdom (UK) who acts on the behalf of a non-UK established manufacturer in relation to the manufacturer's obligations under UK regulations.

# Configuring the *Cardiodrive* System

## System Components

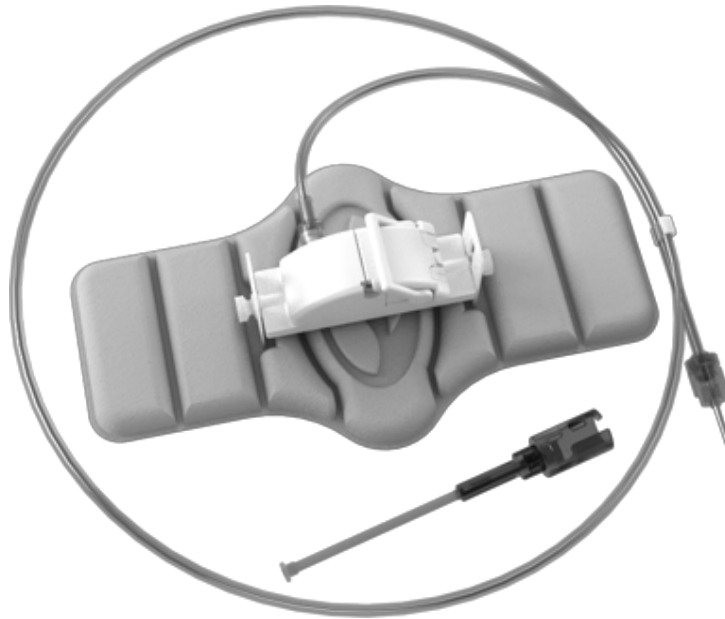
The *Cardiodrive* system consists of three main components:

### Motor Assembly (030-005115)

The Motor Assembly contains the motor, which turns the flexible drive cable that connects to the disposable catheter Advancer Unit.

### Disposable Advancer Unit (001-001751-1)

The *Cardiodrive* system is used with the disposable Advancer Unit (**Figure 1**), which contains the drive assembly for the catheter. The catheter is placed inside the Advancer Unit (also known as the QuikCAS™ device) before the procedure.



**Figure 1.** *Cardiodrive* Advancer Unit

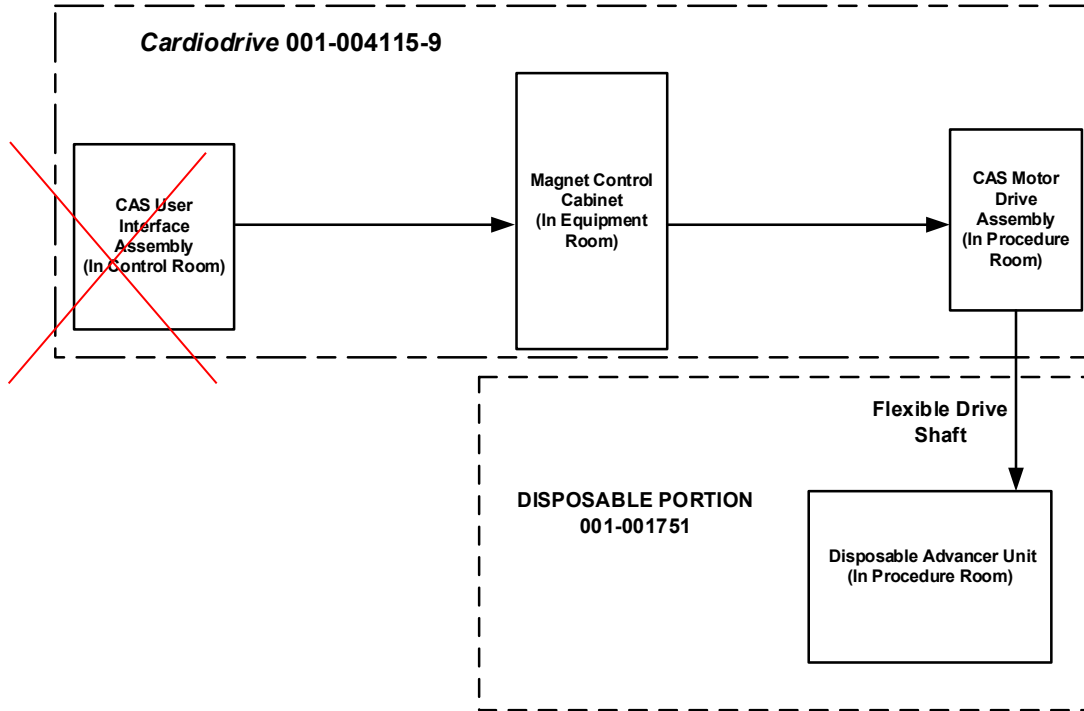


**WARNING:** Do not connect *Cardiodrive* components together while power is applied. Power down the RMNS before connecting the *Cardiodrive* system.

## System Interconnection

The *Cardiodrive* system is to be configured so the Motor Assembly is mounted to the patient table rail. The disposable Advancer Unit is attached to the patient's leg. The flexible drive cable is installed between the motor assembly and the Advancer Unit. The catheter is installed inside the disposable Advancer Unit itself. **Figure 2** displays the interconnection diagram for the *Cardiodrive* system.

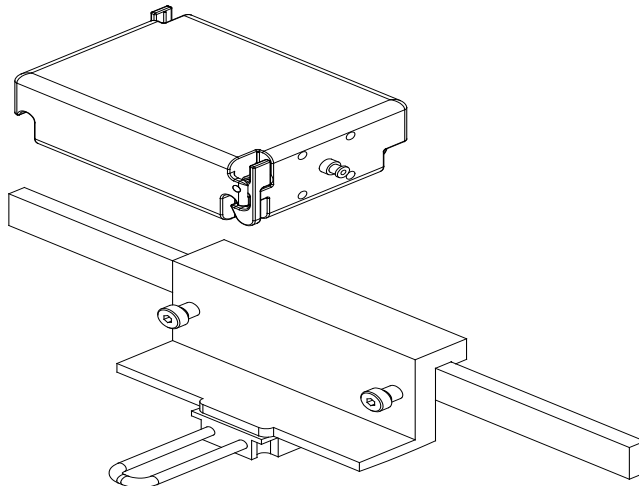




**Figure 2.** Cardiodrive interconnect diagram

## Installing the Motor Assembly Mounting Hardware

- Push the clip in on the Motor Assembly and install on the mounting hardware.
- Attach the Motor Assembly and mounting hardware to the patient table rail as shown in **Figure 3**.



**Figure 3.** Motor Assembly mounting hardware installation

## **Installing the Motor (030-005115)**

- Attach the Motor Assembly to the patient table rail:
  1. Attach the assembly to the rail on the patient's left side (while the patient is lying on his or her back).
  2. Attach the assembly so the motor shaft points toward the patient's head (not toward the feet).
- The motor can be slid along the rail as needed. Its exact position should be adjusted with each patient to take the slack out of the flexible drive cable. This position along the rail varies from patient to patient. Attempt to place it as far toward the patient's feet as practical.

## **Installing the Disposable Advancer Unit (001-001751-1)**

- Refer to the Advancer Unit IFU (**Appendix A: QuikCAS Device**) for installation of the disposable.
- Slide the *Cardiodrive* motor along the patient table rail (toward the patients head or feet) as necessary to take out slack in the flexible drive cable and keep it as straight as possible for a given patient. Attempt to place it as far toward the patient's feet as practical.

## Cardiodrive Instructions for Use

### Powering Up Cardiodrive Unit

- Verify all cables are securely fastened to their appropriate connectors.
- Power up the *Cardiodrive* unit by powering up the RMNS system. Refer to the User Guide for this procedure.
- Test all of the following operations to ensure proper device functioning *before* each use in a surgical procedure.

### Powering Down Cardiodrive Unit

To power down the *Cardiodrive* unit, power down the RMNS system. Refer to the User Guide for this procedure.

## Performance Specifications

Table 3 summarizes the performance specifications for the *Cardiodrive* unit.

**Table 3.** CAS performance specifications

Parameter	Specification
Velocity for remote controlled movement	2.0 cm/sec, maximum
Power supply (supplied by the RMNS system)	24 Volts DC -0%/+10%

### Additional Information

Upon request, Stereotaxis will make available circuit diagrams, component part lists, descriptions, calibration instructions, or other information to assist the user's appropriately qualified technical personnel in repairing the parts of the *Cardiodrive* unit designated by Stereotaxis as repairable.

## Cardiodrive Maintenance

This section outlines the basic procedure for maintenance of the *Cardiodrive* system.

### Cleaning

Do not autoclave any of the *Cardiodrive* components. The *Cardiodrive* electrical equipment is designed to be wiped down with a cloth or swab dampened in common hospital disinfectants. Never submerge any components of the *Cardiodrive* system.

# Index

## A

About user guide .....	2
Advancer Unit.....	6, 10, 12

## C

<i>Cardiodrive</i> system	
About.....	i
Components.....	10
Configuring.....	10
Electromagnetic compatibility information ...	3
Intended use .....	i
Maintenance .....	13
Safety.....	2
CAS.....	6
Cleaning components.....	13
Companion system.....	i
Contact Stereotaxis .....	ii
Contents .....	v

## D

Definitions .....	6
-------------------	---

## E

EC Rep.....	ii
EC Representative .....	ii
Electromagnetic compatibility information .....	3
Electromagnetic immunity .....	4
EMC Directive Statement .....	iii
Emissions .....	3

## F

Figures .....	vi
---------------	----

## I

IFU .....	See Instructions for Use
Instructions for Use .....	2, 6, 13

## M

Magnetic navigation system.....	i
Motor Assembly .....	2, 10, 11, 12

## P

Patents.....	ii
Powering down <i>Cardiodrive</i> unit .....	13
Powering up <i>Cardiodrive</i> unit.....	13
Precautions .....	2

## Q

<i>QuikCAS</i> device .....	10, 12
-----------------------------	--------

## R

Related documents.....	iii
Requesting information.....	13
RF interference immunity.....	5

## S

Safety .....	2
Separation distances.....	6
Symbols.....	7
System components .....	10
System interconnection.....	10

## T

Tables.....	vi
Trademarks.....	iii

## U

User Interface	
Performance specifications .....	13

## W

Warnings.....	2
Waste and Recycling.....	iii